

## RT830B Integration guide



technology

Chapter 1 Introduction.....	5
1.1 Product Overview .....	5
1.2 Illumination.....	6
Chapter 2 Installation.....	7
2.1 General Requirements.....	7
2.1.1 ESD .....	7
2.1.2 Dust and Dirt.....	7
2.1.3 Ambient Environment .....	7
2.1.4 Thermal Considerations.....	8
2.2 Optics .....	8
2.2.1 Window Placement .....	8
2.2.2 Window Material and Color .....	9
2.2.3 Scratch Resistance and Coating .....	9
2.2.4 Window Size .....	9
2.2.5 Ambient Light .....	10
2.2.6 Eye Safety.....	10
2.2.7 Mounting.....	10
Chapter 3 Electrical Specifications .....	11
3.1 Power Supply .....	11
3.2 Ripple Noise .....	11
3.3 DC Characteristics .....	11
3.3.1 Operating Voltage .....	11
3.3.2 Current.....	12
Chapter 4 Interfaces.....	13
4.1 Host Interface Connector .....	14
4.2 Flat Flexible Cable.....	14
4.3 Communication Interfaces .....	15
4.4 Control Interfaces.....	15
4.4.1 Trigger.....	15
4.4.3 Decode LED .....	17

# Chapter 1 Introduction

## 1.1 Product Overview

RT830B series 2D barcode scan engines, a computerized image recognition system, bring about a new era of 2D barcode scan engines.

The RT830B decoder ingeniously blends an advanced chip design & manufacturing, which significantly simplifies application design and delivers superior performance and solid reliability with low power consumption.

The RT830B support all mainstream 1D and standard 2D barcode symbologies (e.g UPC/EAN, UPC/EAN with supplementals, Bookland EAN, ISSN, UCC Coupon Extended Code, Code128, GS1-128, ISBT 128, Code 39 )as well as (PDF417, MicroPDF417, Composite Codes, Data Matrix, Maxicode, QR Code, Micro QR, Aztec).

<b>Physical Characteristics</b>	
Dimensions:	65mmX61.5mmX29mm
Weight:	50g
Voltage:	DC:4.7V~5.3V
Current:	40mA (standby); <2mA (Sleep mode)
<b>Performance Characteristics</b>	
Light Source:	illumination: 5600K LED
Field of View:	115° (H) x 90° (V)
Roll / Pitch / Yaw:	360°, ±65°, ±60°
Print Contrast:	20% minimum reflective difference
<b>Symbology Decode Capability</b>	
1-D:	UPC/EAN, UPC/EAN with supplementals, Bookland EAN, ISSN, UCC Coupon Extended Code, Code128, GS1-128, ISBT 128, Code 39, Code 39 Full ASCII, Trioptic Code 39, Code 32, Code 93, Code11, Matrix 2 of 5, Interleaved 2 of 5, Discrete 2 of 5, Codabar, MSI, Chinese 2 of 5, GS1 DataBar variants, Korean 3 of 5, ISBT Concat
2-D:	PDF417, MicroPDF417, Composite Codes, Data Matrix, Maxicode, QR Code, MicroQR, Aztec
DOF	20mil QR:0~50mm ,13mil UPC:0~45mm
Minimum Resolution	5 mil Code39
Interfaces Supported:	USB, 232

<b>User Environment</b>	
Operating Temperature:	32° to 122° F / 0° to 50° C
Storage Temperature:	-40° to 158° F / -40° to 70° C
Humidity:	5% to 95%, non-condensing
Drop/Shock Specifications:	Withstands 10Gs 0.06" double amp
Ambient Light Immunity:	Immune to indoor lighting up to 1600 Lux. Immune to sunlight up to 86,000 Lux.

## 1.2 Illumination

The RT830B has one white LED (5600K) for supplementary lighting, making it possible to scan barcodes even in complete darkness. The illumination can be programmed On or Off.

The RT830B's LEDs imaging system is designed to work better with white light, so the engine shows better reading performance on barcodes printed in color. The user can conduct some tests to determine the proper wavelengths to be used.

# Chapter 2 Installation

## 2.1 General Requirements

### 2.1.1 ESD

ESD protection has been taken into account when designing the RT830B and the engine is shipped in ESD safe packaging. Always exercise care when handling the engine outside its package. Be sure grounding wrist straps and properly grounded work areas are used.

### 2.1.2 Dust and Dirt

The RT830B must be sufficiently enclosed to prevent dust particles from gathering on the imager and lens. Dust and other external contaminants will eventually degrade the engine's performance.

### 2.1.3 Ambient Environment

The following environmental requirements should be met to ensure good performance of the RT830B:

WorkingTemperature	0°C to 50°C
StorageTemperature	-40°C to 70°C
Humidity	5% ~95% (non-condensing)

## 2.1.4 Thermal Considerations

Electronic components in the RT830B generate heat during the course of their operation. Operating the RT830B in continuous mode for an extended period may result in an increase in temperature by 20 °C inside the engine. The following precautions should be taken when integrating the RT830B:

Reserve sufficient space for good air circulation during design.

Avoid wrapping the RT830B with thermal insulation materials such as rubber.

## 2.2 Optics

### 2.2.1 Window Placement

The window should be positioned properly to let the illumination and aiming beams pass through as much as possible and no reflections back into the engine (reflections can degrade the reading performance).

The window should be mounted close to the front of the engine (parallel). The maximum distance is measured from the front of the engine cover to the farthest surface of the window. Avoid unwanted reflections and use thin material for window so as to reach better reading performance. The distance from the front of the engine cover to the furthest surface of the window should not exceed 0.5mm and its better to make the window contact with the engine rubber cover.

If the window is required to be in a tilted position, the above distance requirements should be met and tilt angle should ensure no reflections back into the lens.

## 2.2.2 Window Material and Color

Wavelengths of illumination and aiming beams should be taken into consideration when choosing window material and color, to achieve the possible highest spectral transmission and lowest blurriness. It is suggested PMMA or optical glass with spectral transmittance over 90% and blurriness less than 1%. Whether to use an anti-reflection coating or not depends on the material and application needs.

## 2.2.3 Scratch Resistance and Coating

Scratch on the window can greatly reduce the performance of the RT830B. It is suggested to use abrasion resistant window material or coating.

## 2.2.4 Window Size

The window must not block the field of view and should be sized to accommodate the aiming and illumination envelopes shown below.

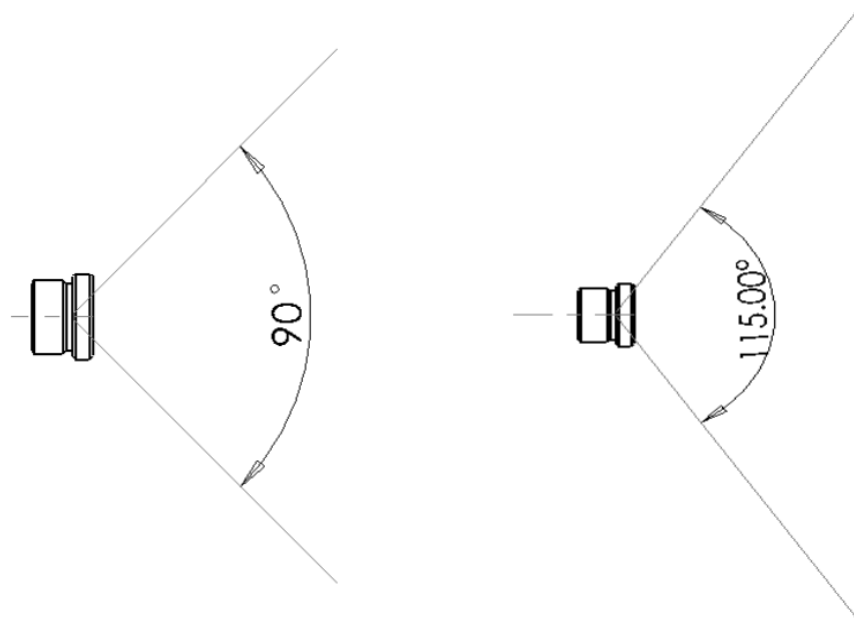

## 2.2.5 Ambient Light

The RT830B may show better performance with ambient light. However, high-frequency pulsed light can result in performance degradation.

## 2.2.6 Eye Safety

The RT830B has LEDs what create the aiming and illumination beams. These LEDs are bright, but testing has been done to demonstrate that the engine is safe for its intended application under normal usage conditions. However, the user should avoid looking into the beam.

## 2.2.7 Mounting

RT830B Engine includes motherboard and Engine camera board assembly. The two components are Integrated in one piece.

The illustrations below show the mechanical mounting dimensions for the RT830B. The structural design should leave some space between components and provide sufficient space for flat flexible cable.

Elements listed in previous sections should also be taken into consideration when integrating the RT830B.



**Front View (unit: mm)**

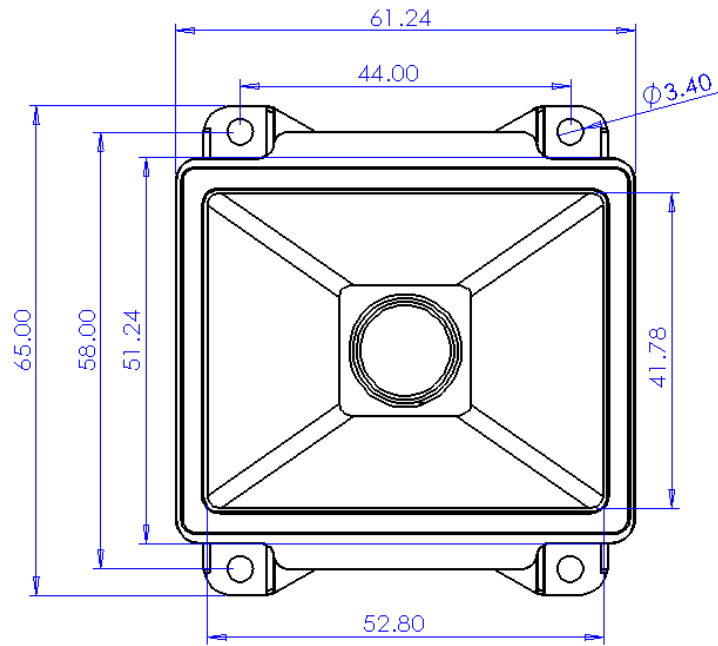

**Left View (unit: mm)**

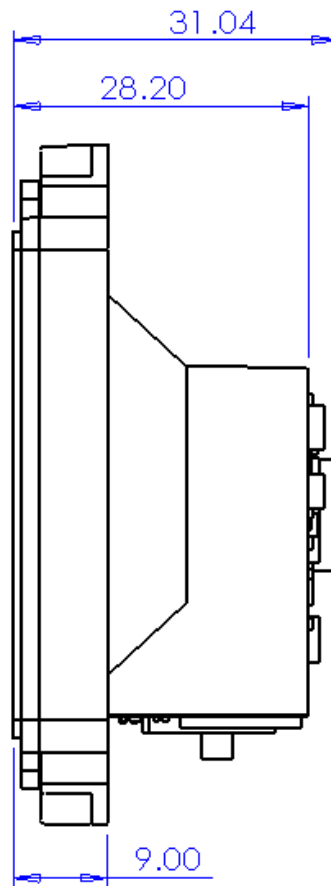

# Chapter 3 Electrical Specifications

## 3.1 Power Supply

Do not power up the RT830B until it is properly connected. Be sure the power is cut off before connecting a flexible cable to or disconnecting a flexible cable from the host interface connector. This could damage the engine.

Unstable power supply or sharp voltage drops may lead to unstable performance of the engine. Do not resupply the power immediately after cutting it off. The interval must be greater than 3 seconds.

## 3.2 Ripple Noise

To ensure the image quality, a power supply with low ripple noise is needed. Acceptable ripple range (peak-to-peak) :  $\leq 50\text{mV}$  ( $\leq 30\text{mV}$  recommended).

## 3.3 DC Characteristics

### 3.3.1 Operating Voltage

$T_a = 25^\circ\text{C}$ :

	MIN	Tpy	MAX	
$V_{CC}$	3.3	5	5.5	V
$V_{IH}$	$V_{CC}-0.5$	-	-	V
$V_{IL}$	-	-	0.5	V
$V_{OH}$	$V_{CC}-0.3$	-	-	V
$V_{OL}$	-	-	0.3	V

### 3.3.2 Current

Ta=25°C, VCC=5V

Parameter	Average	Maximum	Unit
I <sub>OP</sub>	150	300	mA
I <sub>Standby</sub>	40	-	mA

# Chapter 4 Interfaces

The following table lists the pin functions of the 12-pin host interface connector.

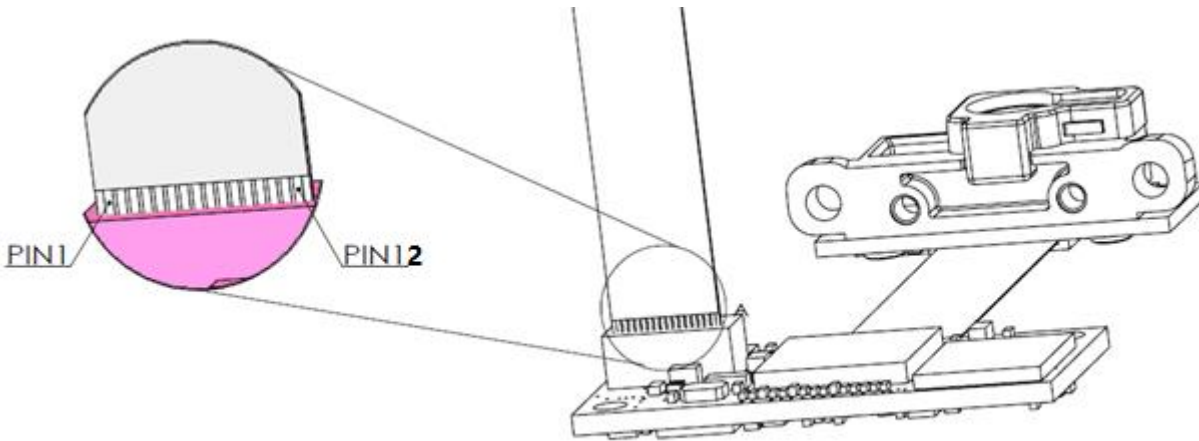

PIN#	Signal Name	I/O	Function
1	NC	-	
2	VCC	-	Power supply
3	GND	-	Ground
4	RX	Input	TTL-232 receiving
5	TX	Output	TTL-232 transmission
6	D-	Input/ Output	USB D- differential data signal
7	D+	Input/ Output	USB D+ differential data signal
8	NC	-	
9	BUZ	Output	Beeper output. For the information of beeper
10	LED1	Output	Decode LED output. For the information of LED driver circuit, see the <b>“Control Interfaces”</b> section.
11	LED2	Input	Decode LED2 output. For the information of LED driver circuit, see the <b>“Control Interfaces”</b> section.
12	TRIG	Input	Trigger signal input: Driving this pin low for at least 10ms, causes the SE3102-C to start a scan and

## 4.1 Host Interface Connector

The RT830B's host interface connector is a 12-pin NONE ZIF socket which can be used to connect a host device (e.g., RT830B software development board EVK) with a flat flexible cable. The following figures show the position and dimensions of the socket. (unit: mm)

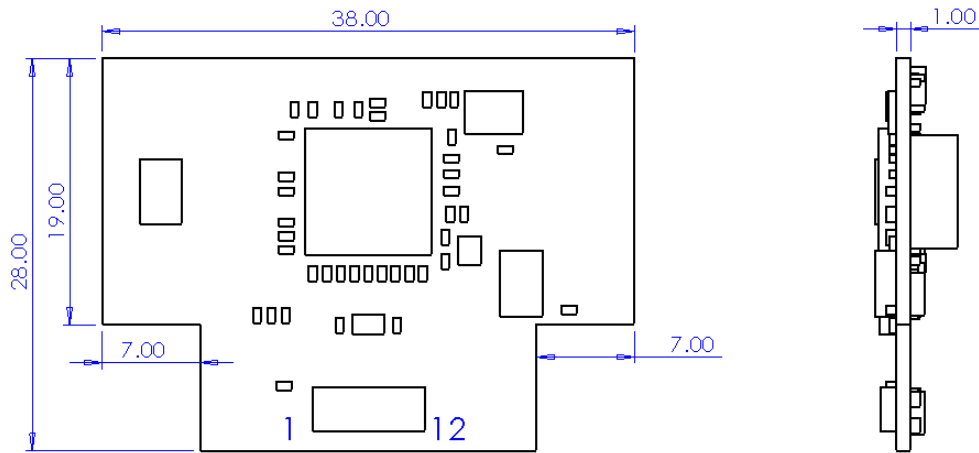

## 4.2 Flat Flexible Cable

A 12-pin flat flexible cable can be used to connect the RT830B to OEM equipment or to the RT830B EVK. The cable design must be consistent with the following specifications shown below. Use reinforcement material for the connectors on the cable and reduce cable impedance for reliable connection and stable performance.

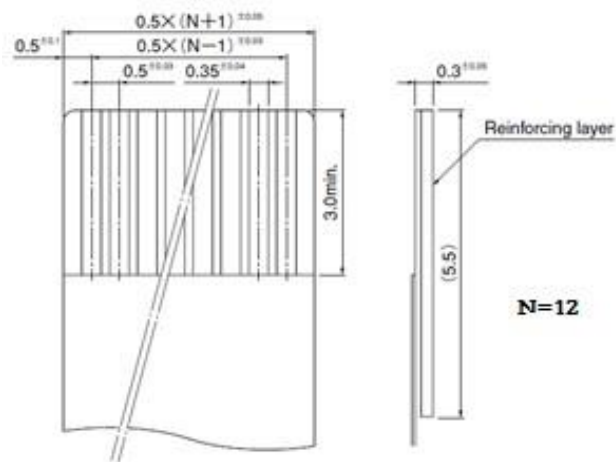

## 4.3 Communication Interfaces

The RT830B can communicate with the host device through either TTL-232 serial port or USB port. It provides 3 communication modes:

### **TTL-232:**

This interface is applicable to most system architectures. For those requiring RS232, a TTL-232 to RS232 conversion circuit is needed.

### **USB HID-KBW:**

Based on USB connection, the engine's transmission is simulated as USB keyboard input. It works on a Plug and Play basis and no driver is required.

### **USB COM Port Emulation:**

The USB port on the host device is emulated as a serial port with the same data transmission and configuration as a real serial port. A driver is required.

## 4.4 Control Interfaces

### 4.4.1 Trigger

Driving the TRIG pin (PIN 12) on the host interface connector low for a specified time period causes the RT830B to start a scan and decode session. The time period varies from one scan mode to another. Anti-shake mechanism is used in level trigger mode. Trigger is activated in this mode if the signal from the TRIG pin remains low for at least 10ms.

For those scan modes with a timeout mechanism, the engine can automatically deactivate the trigger when a timeout occurs. After one trigger, the engine gets ready for next trigger only if the signal from the TRIG pin remains high for at least 10ms.

## 4.4.2 Beeper

The RT830B provides a pin (BUZ, PIN 9) on the host interface connector that provides a PWM output to an external driver circuit for generating audible feedback to the user to indicate statuses like power up, good decode or operation mistake. The PWM output is not strong enough to drive a beeper, so a beeper driver circuit is needed.

The following beeper driver circuit is provided for reference.

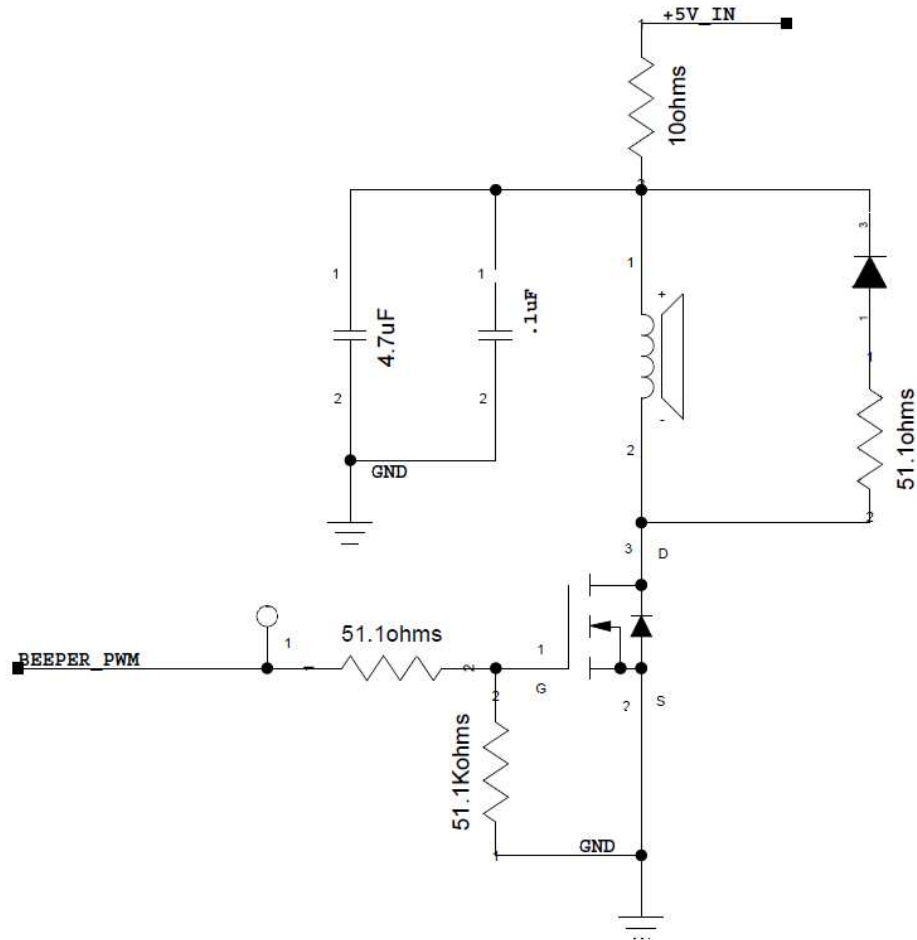

### 4.4.3 Decode LED

The RT830B provides a pin (LED, PIN 10, PIN 11) on the host interface connector that can be used by an external driver circuit to drive an LED to indicate a Good Decode status. When a good decode occurs, the signal from the LED pin turns from a low level into alternation of high and low levels and then back into a low level. This Decode LED output is not strong enough to drive an LED, so an LED driver circuit is needed.

The following decode LED driver circuit is provided for reference.

