

RT208

OEM Scan Engine

Integration Guide



Table of Contents

Chapter 1 Introduction.....	1
Overview	1
Illumination	1
Aimer	1
Chapter 2 Installation.....	2
General Requirements.....	2
ESD.....	2
Dust and Dirt.....	2
Thermal Considerations.....	3
Installation Orientation	3
Optics	4
Window Placement.....	4
Window Material and Color	4
Scratch Resistance and Coating	5
Window Size	5
Ambient Light.....	6
Eye Safety.....	6
Mounting.....	7
Front View (unit: mm)	7
Side View (unit: mm).....	7
Top View (unit: mm).....	8
Chapter 3 Electrical Specifications	9
Power Supply	9
Ripple Noise.....	9
DC Characteristics	10
Operating Voltage.....	10
Operating Current	10

Chapter 4 Interfaces	11
Host Interface Connector	11
Dimensions of the Host Interface Connector (unit: mm)	12
FFC Cable (unit: mm)	13
Communication Interfaces	14
Control Interface.....	15
Reset.....	15
Trigger.....	15
Beeper	16
Good Read LED	17
Chapter 5 Development Tools	18
EVK	18

Chapter 1 Introduction

Overview

The RT208 supports all mainstream 1D as well as PDF417, QR Code (QR1, QR2, Micro QR), Chinese Sensible Code, Data Matrix and GS1-DataBar™(RSS) (Limited/ Stacked/ Expanded versions).

Illumination

The RT208 has two red LEDs for supplementary lighting. The illumination can be programmed On or Off.

The RT208 uses red LEDs for illumination, so the engine shows better reading performance on barcodes printed in non-red colors. For applications involving red barcodes, it is advised to turn off the engine's illumination and use non-red supplementary lighting (such as green) instead. The user can conduct some tests to determine the proper wavelengths to be used.

Aimer

The RT208 contains a laser aimer that produces a crosshair aiming pattern to help the user to easily position the target barcode within the engine's field of view to increase scan efficiency. The aiming pattern can be turned On or Off. It is advisable to turn it on when scanning barcodes.

Chapter 2 Installation

General Requirements

ESD

ESD protection has been taken into account when designing the RT208 and the engine is shipped in ESD safe packaging. Always exercise care when handling the engine outside its package. Be sure grounding wrist straps and properly grounded work areas are used.

Note: The RT208's laser diode (circled in the figure below) is ESD sensitive and rated Class 1A Human Body Model (HBM) 270V, thus ESD protection measures, such as the ones mentioned above, must be taken when handling or installing the RT208 to avoid damage to the laser diode.



Dust and Dirt

The RT208 must be sufficiently enclosed to prevent dust particles from gathering on the lens, circuit boards and LEDs. Dust and other contaminants will eventually degrade the engine's performance.

Thermal Considerations

Electronic components in the RT208 will generate heat during the course of their operation. Operating the RT208 continuously for an extended period may cause temperatures to rise on CIS and decoder chip. The following precautions should be taken into consideration when integrating the RT208.

- ❖ Reserve sufficient space for good air circulation in the design.
- ❖ Avoid wrapping the RT208 with thermal insulation materials such as rubber.

Installation Orientation

There are two threaded mounting holes in the bottom of the RT208 for fastening the engine to a mounting surface with machine screws. The following figure illustrates a front view of the RT208 after correct installation.

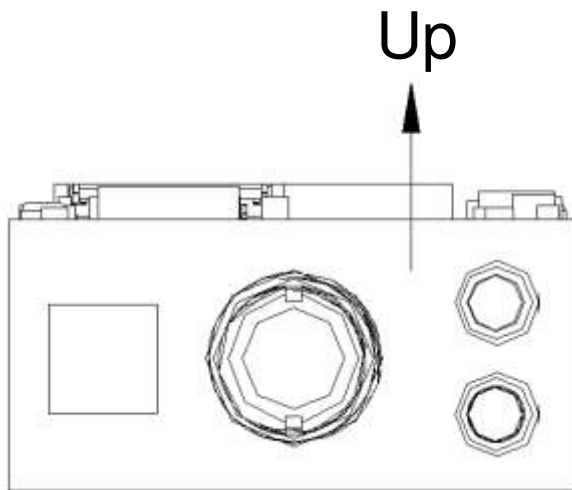

Optics

Window Placement

The window should be positioned properly to let the illumination and aiming beams pass through as much as possible and no reflections back into the engine (reflections can degrade the reading performance).

The window should be mounted close to the front of the engine (parallel). The maximum distance is measured from the front of the engine housing to the furthest surface of the window. Avoid unwanted reflections and use thin material for window so as to reach better reading performance. As shown in the figure below, the distance from the front of the engine housing to the furthest surface of the window should not exceed 3mm and the distance from the front of the engine housing to the nearest surface of the window should not exceed 2mm.

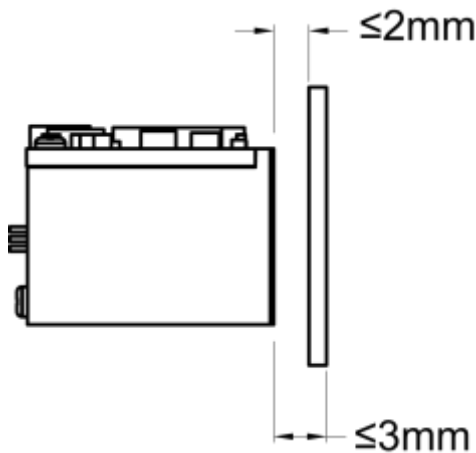

If the window is required to be in a tilted position, the above distance requirements should be met and tilt angle should ensure no reflections back into the lens.

Window Material and Color

CIS's responsiveness (mainly to wavelengths of red light) should be taken into consideration when choosing window material and color, in order to achieve the possible highest spectral transmission, lowest haze level and homogeneous refractive index. It is suggested to use PMMA or optical glass with spectral transmittance of red light over 90% and haze less than 1%. Whether to use an anti-reflection coating or not depends on the material and application needs.

Scratch Resistance and Coating

Scratch on the window can greatly reduce the performance of the RT208. It is suggested to use abrasion resistant window material or coating.

Window Size

The window must not block the field of view and should be sized to accommodate the aiming and illumination envelopes shown below.

Horizontal:

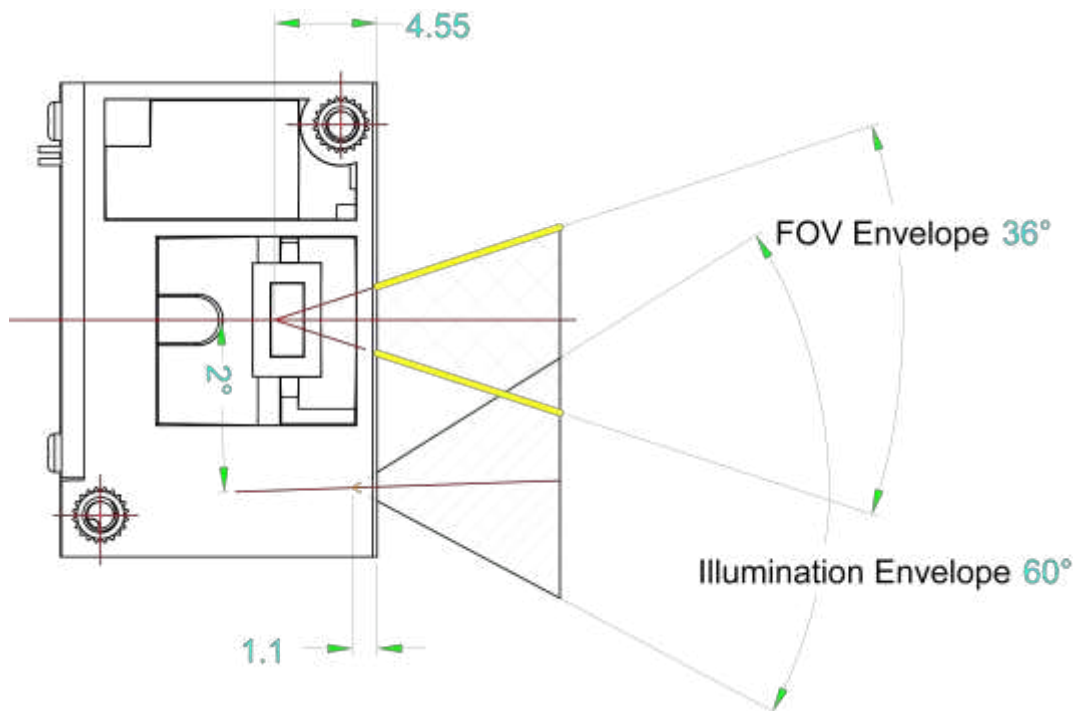

Vertical:

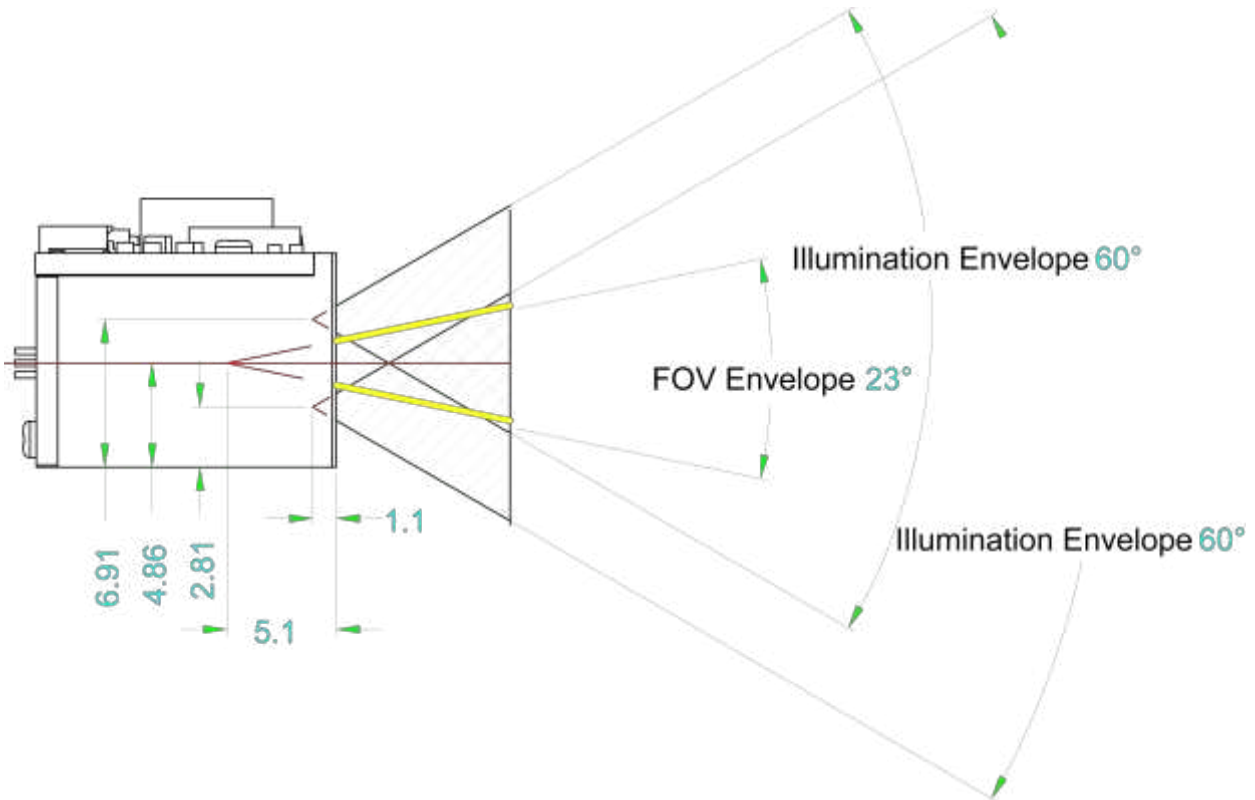

Ambient Light

The RT208 shows better performance with ambient light and it is well able to handle the flicker in fluorescent lights using 50-60Hz AC power. However, high-frequency pulsed light can result in performance degradation.

Eye Safety

The RT208 uses red LEDs to create illumination beam. The LEDs are bright, but testing has been done to demonstrate that the engine is safe for its intended application under normal usage conditions. However, the user should avoid looking into the beam.

The RT208 uses a laser diode to form a bright, intuitive aiming aid. It is hazardous to stare into the laser beam.

Mounting

The illustrations below show the mechanical mounting dimensions for the RT208. The structural design should leave some space between components.

Front View (unit: mm)

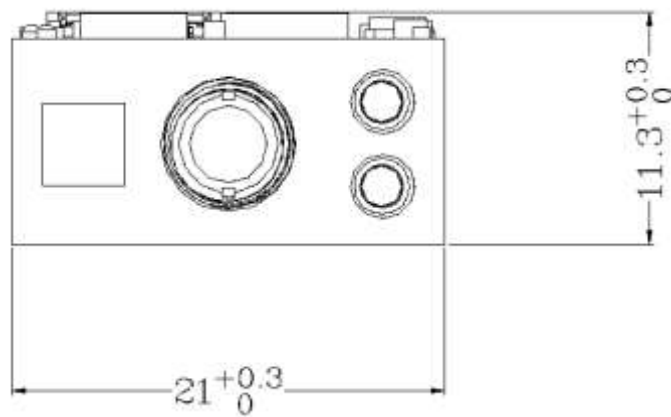

Side View (unit: mm)

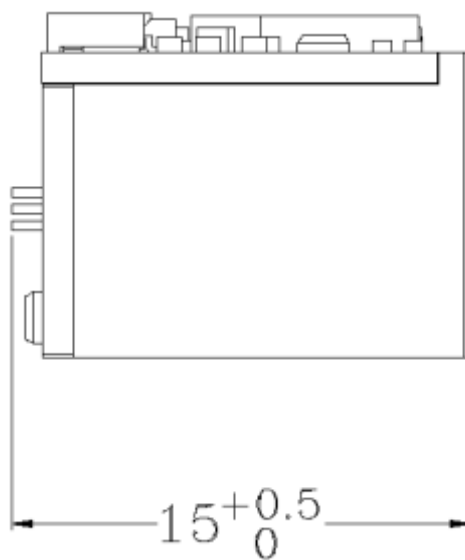

Top View (unit: mm)

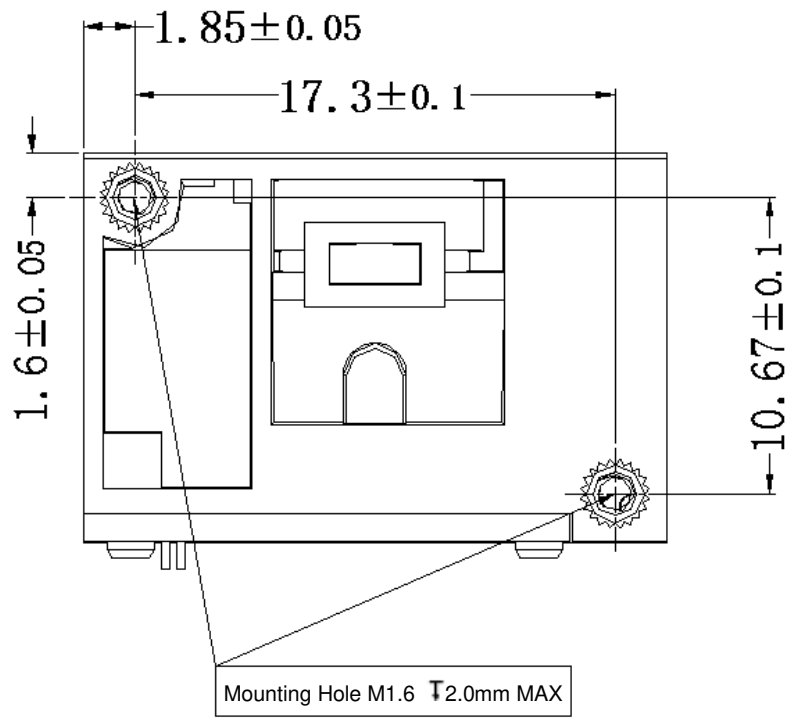

Chapter 3 Electrical Specifications

Power Supply

Do not power up the RT208 until it is properly connected. Be sure the power is cut off before connecting a flexible cable to or disconnecting a flexible cable from the host interface connector. Hot-plugging could damage the engine.

Unstable power supply or sharp voltage drops or unreasonably short interval between power-ons may lead to unstable performance of the engine. Do not resupply the power immediately after cutting it off. The minimum interval must exceed 2 seconds.

Ripple Noise

Image sensor and decoder chip are directly fed by the input power of RT208. To ensure the image quality, a power supply with low ripple noise is needed.

Acceptable ripple range (peak-to-peak) : $\leq 50\text{mV}$ ($\leq 30\text{mV}$ recommended).

DC Characteristics

Operating Voltage

Ta=25°C

Parameter	Description	Minimum	Typical	Maximum	Unit
V _{DD}	Voltage Drain Drain	3.0	3.3	3.6	V
V _{IH}	High Level Input Voltage	V _{DD} -0.5	-	-	V
V _{IL}	Low Level Input Voltage	-	-	0.5	V
V _{OH}	High Level Output Voltage	V _{DD} -0.3	-	-	V
V _{OL}	Low Level Output Voltage	-	-	0.3	V

Operating Current

Ta=25°C, V_{DD}=3.3V

Operating Current	Standby Current	Sleep Current
142mA (typical) 204mA (max.)	10.2mA	<100uA

Chapter 4 Interfaces

Host Interface Connector

The following table lists the pin functions of the 12-pin host interface connector of the RT208.

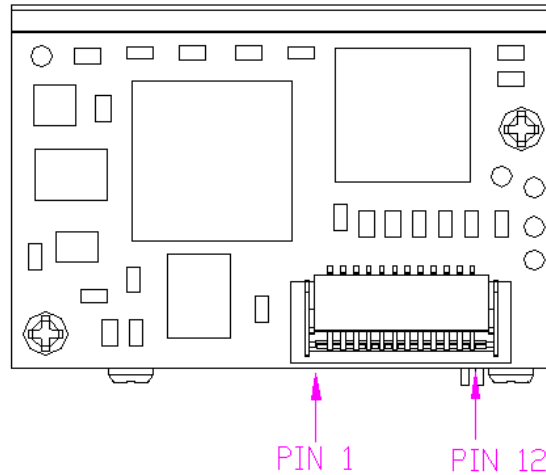

PIN#	Signal Name	I/O	Function
1	NC	-	Not connected.
2	VDD	-	3.3V power supply.
3	GND	-	Power-supply ground.
4	RX	I	TTL level 232 receive data.
5	TX	O	TTL level 232 transmit data.
6	USB_D-	I/O	USB_D- differential data signal. (optional)
7	USB_D+	I/O	USB_D+ differential data signal. (optional)
8	NC	-	Not connected.
9	Buzz	O	Beeper output. For the information of beeper driver circuit, see the Beeper section in this chapter.
10	LED	O	Good Read LED output. For the information of LED driver circuit, see the Good Read LED section.
11	Reset	I	Reset signal input: Driving this pin low for 100us-500us resets the engine.
12	nTrig	I	Trigger signal input: Driving this pin low for at least 10ms causes the RT208 to start a scan and decode session.

Dimensions of the Host Interface Connector (unit: mm)

The RT208 uses a 12-pin FPC ZIF socket (bottom contact, model: 10051922-1210EHLF) manufactured by FCI. The socket can be connected to a host device with a FFC cable.

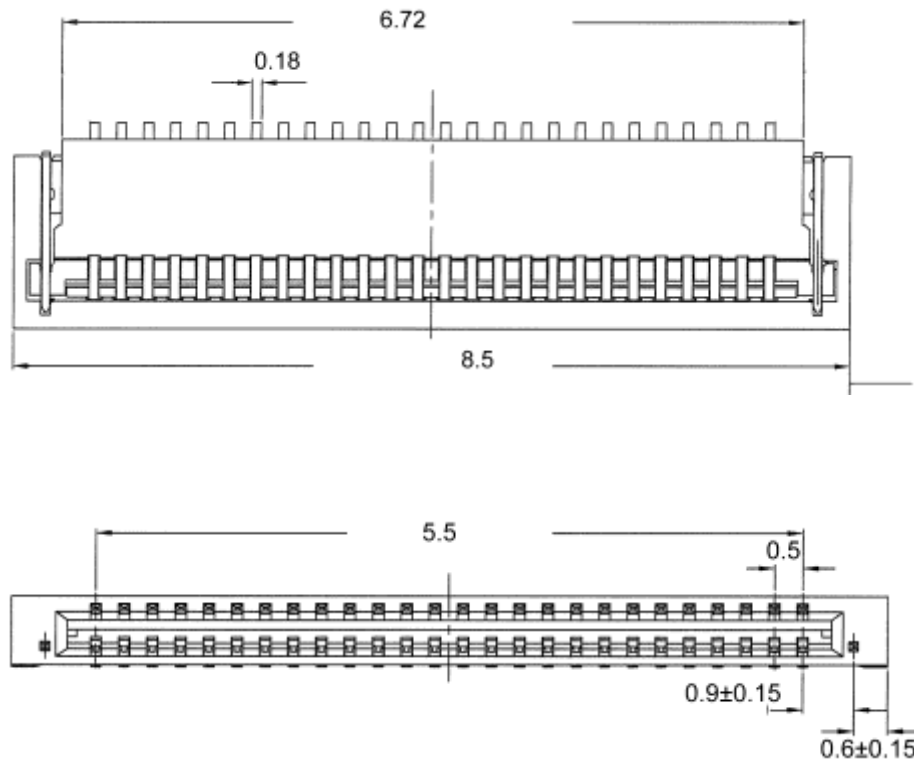

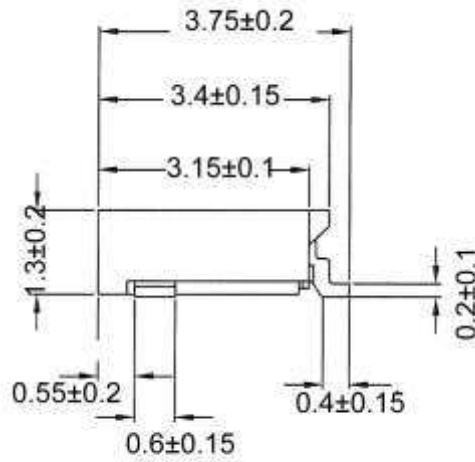

FFC Cable (unit: mm)

A 12-pin FFC cable can be used to connect the RT208 to a host device. The cable design must be consistent with the specifications shown below. Use reinforcement material for the connectors on the cable and reduce cable impedance for reliable connection and stable performance.

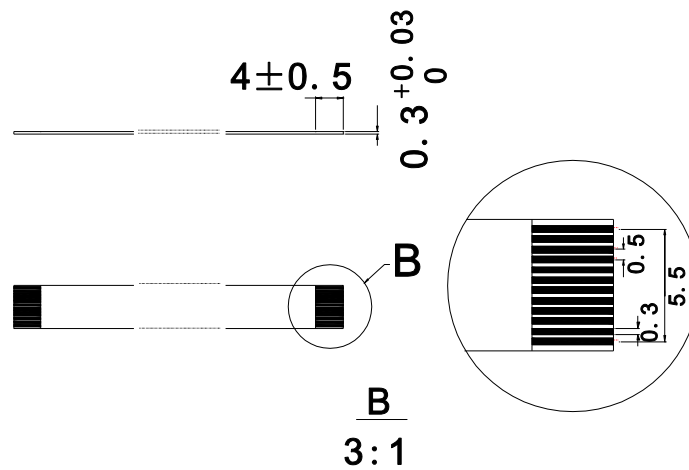

Communication Interfaces

The RT208 can communicate with the host device via its TTL-232 interface. This interface is applicable to most system architectures. For those requiring RS-232, a TTL-232 to RS-232 conversion circuit is needed.

The RT208's TTL-232 interface supports baud rates from 1200bps to 115200bps; it does not support hardware flow control. Its default settings are 9600bps, 8 data bits, no parity check and 1 stop bit.

Besides, the RT208 can also communicate with the host device via its USB interface (optional).

1. **USB HID-KBW:** Based on USB connection, the engine's transmission is simulated as USB keyboard input. It works on a Plug and Play basis and no driver is required.
2. **USB COM Port Emulation:** The USB interface on the host device is emulated as a serial port with the same data transmission and configuration as a real serial port. A driver is required.
3. **USB HID-POS:** It is based on HID with no need for custom driver and is way more efficient in communication than keyboard emulation and traditional RS-232 interface.

Control Interface

Reset

Driving the Reset pin (PIN 11) on the host interface connector low for 100us-500us can reset the RT208. However, do not reset the engine at unreasonably short intervals. The minimum interval between resets must exceed 2 seconds.

Trigger

Driving the nTrig pin (PIN 12) on the host interface connector low for over 10ms causes the RT208 to start a scan and decode session. If barcode is decoded, the RT208 waits for the voltage at the nTrig pin to turn high (or the trigger to be released) after sending the data to the Host. If the trigger is released during a scan attempt, the RT208 immediately stops decoding.

Next decode session does not happen until the RT208 receives active trigger signal (by driving the nTrig pin low) again.

As a decode session involves image capture, barcode decoding and other steps, it is suggested that the minimum interval between triggers should exceed 50ms.

The following trigger circuit is provided for reference.

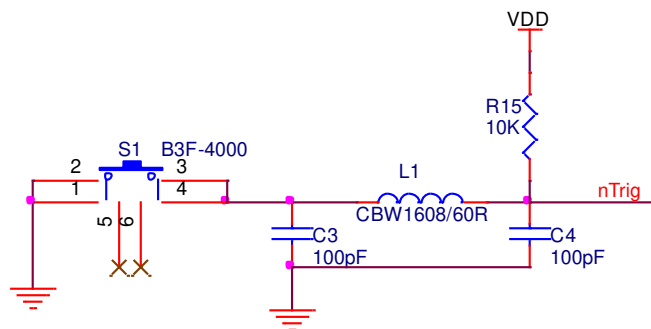

Beeper

The RT208 provides a pin (Buzz, PIN 9) on the host interface connector that provides a PWM output to an external driver circuit for generating audible feedback to the user to indicate statuses like power up or good read. The PWM output is not strong enough to drive a beeper, thus a beeper driver circuit is needed.

The following beeper driver circuit is provided for reference.

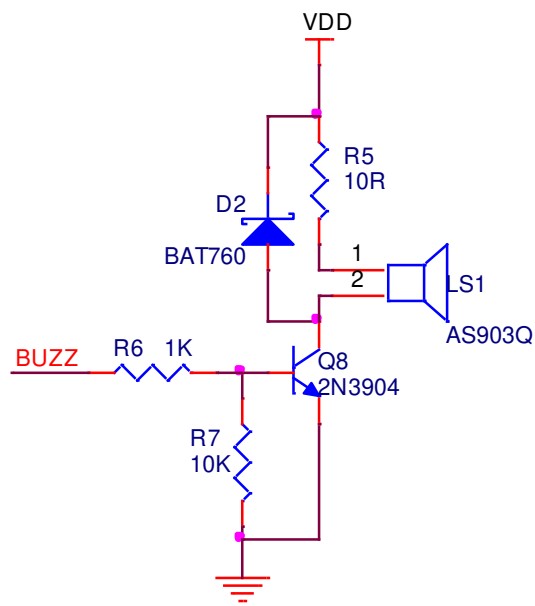

Good Read LED

The RT208 provides a pin (LED, PIN 10) on the host interface connector that can be used by an external driver circuit to drive an LED to indicate a Good Read status. When a good read occurs, the LED pin produces a high level output for about 300ms, and then the signal is back to a low level. This Good Read LED output is not strong enough to drive an LED, so an LED driver circuit is needed.

The following Good Read LED driver circuit is provided for reference.

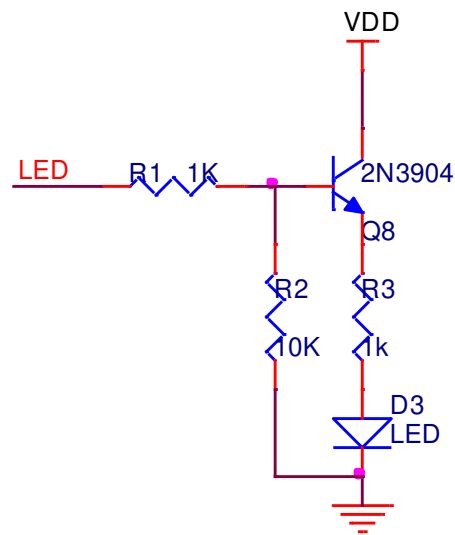

Chapter 5 Development Tools

EVK

The EVK is provided to help users to test and evaluate the RT208, which contains beeper & beeper driver circuit, LED & LED driver circuit, trigger & reset button, TTL-232 to RS-232 converter & TTL-232 to USB converter, RS-232 & USB interfaces, etc. The RT208 can be connected to the EVK via a 12-pin FFC cable type 1 (contacts on the same side). Either USB connection or RS-232 connection can be used when connecting the EVK to a host device.